

Spain Nationals 2026

Test Project

Robot Systems Integration

Independent Test Project Re-Designer: Karla Kosch

Contents

Introduction to Test Project.....	3
Introduction - Description (F).....	3
Introduction – Education Cell (F).....	3
Introduction – Safety (F).....	4
Description of Test Project Resources.....	6
Description – Basic Task Parts (F).....	6
Description – Gripper and Teach Pin (F).....	9
Description – I/O Block (F).....	10
Description – UOP Box (F).....	11
Description – PC and Software (F).....	12
Description – Ethernet (F).....	12
Description – Basic HMI (F).....	13
Description – Advanced HMI (F).....	13
Description – Reserved Programs (F).....	14
Instructions to the Competitor.....	15
Instructions – Basic Task - Parts (C1).....	15
Instructions – Robot Setup – Gripper (C1).....	16
Instructions – Gripper Test Run (C1).....	17
Instructions – Basic Task (C2).....	18
Instructions – Basic Task Sequence (C2).....	19
Instructions – Extension Task (C3).....	20
Instructions – Working Style and Safety (F).....	23
Instructions - Roboguide/Digital Twin (F).....	23
Instructions –Documentation (F).....	23
Instructions – Robot and PC Power (F).....	23
Instructions – Test Running and Test Run Timer (F).....	24
Materials, equipment, and tools prohibited in the skill Area (F).....	25

Introduction to Test Project

Introduction - Description (F)

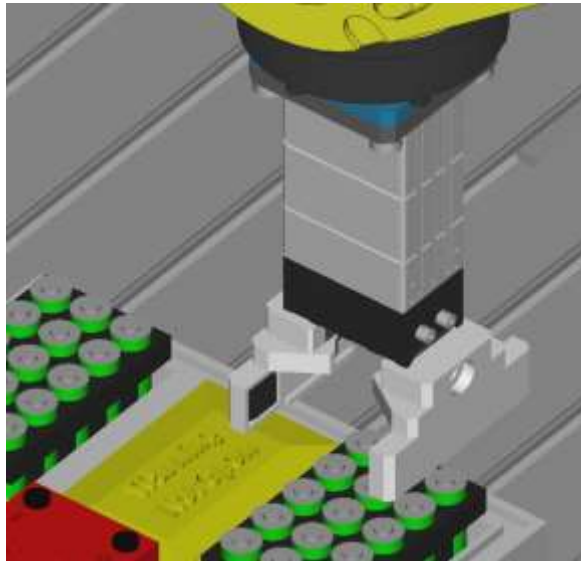

The Project is to set up a system to automatically assemble an Electric Vehicle (EV) Battery Pack. The Project is divided into stages, setting up the robot and the cell, completing the basic task and then attempting extension task if the competitors have time.

Introduction – Education Cell (F)



The competition is based upon the standard FANUC Europe Education Cell.

The Education Cell is delivered 'ready to run' – there is no need for the Competitors to physically install the robot or connect input power.

But the Competitors must decide on the layout of the cell components and install, connect, and configure all cell equipment.

Introduction – Safety (F)

Each Expert is responsible for the safety of their team

The Competitor's bodies must not enter the cell while moving the robot or manipulating the teach pendant.

Examples:

OK

Body is outside of the cell while moving the robot.



OK

Body is partially inside the cell, but TP is on hook.

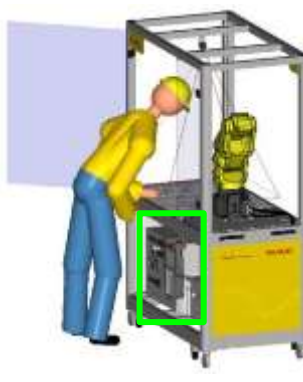

Not OK

Body is partially inside the cell while moving the robot.



The Competitors must always be able to take a step back when working in the cell or moving the robot in case something unexpected happens.

Examples:

OK



Not OK



Not OK



AUTO/T1/T2 Switch

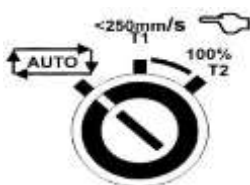

Competitors should do all setup/programming etc in T1 mode (<math><250\text{ mm/s}</math>)

For Testing, the competitors can use Auto, T2 or T1 Mode.

For T1 or T2 Mode the Cell door can be Open or Closed.

For this Competition the Competitors are responsible for the Auto/T1/T2 key.

Controller Access/Open Controller Door

If there is a reason for the Competitors to open the controller door, this will be explicitly stated in the Test Project Description. Otherwise, the controller door should remain closed.

But in case Competitors request, for instance to check a proper Ethernet connection, the door may be opened **by FANUC Technical Support Staff or two Experts.**

Power must be turned off before opening controller!

OK

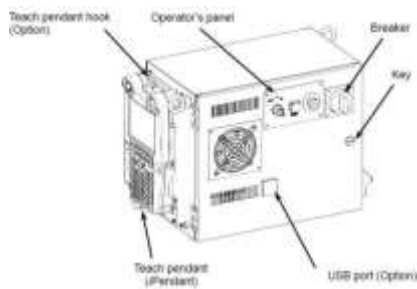

Not OK

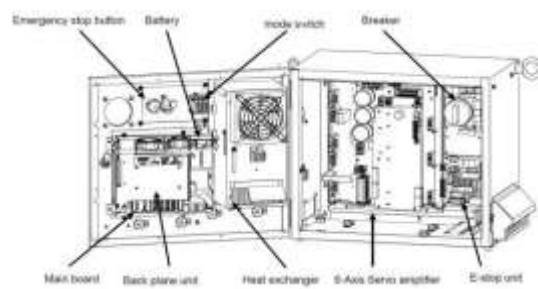

Description of Test Project Resources

Description – Basic Task Parts (F)

Battery Pack Body 2x3 (x1)

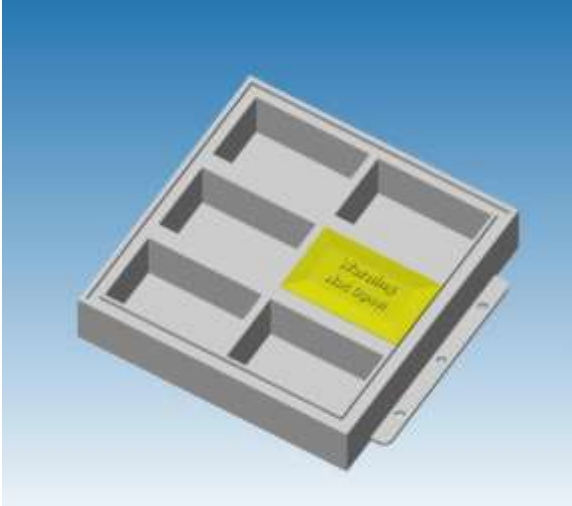

Battery Pack Lid (x1)

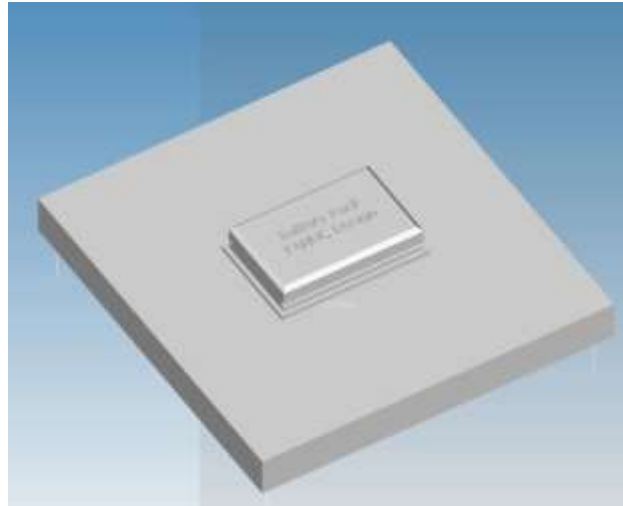

Module Magazine

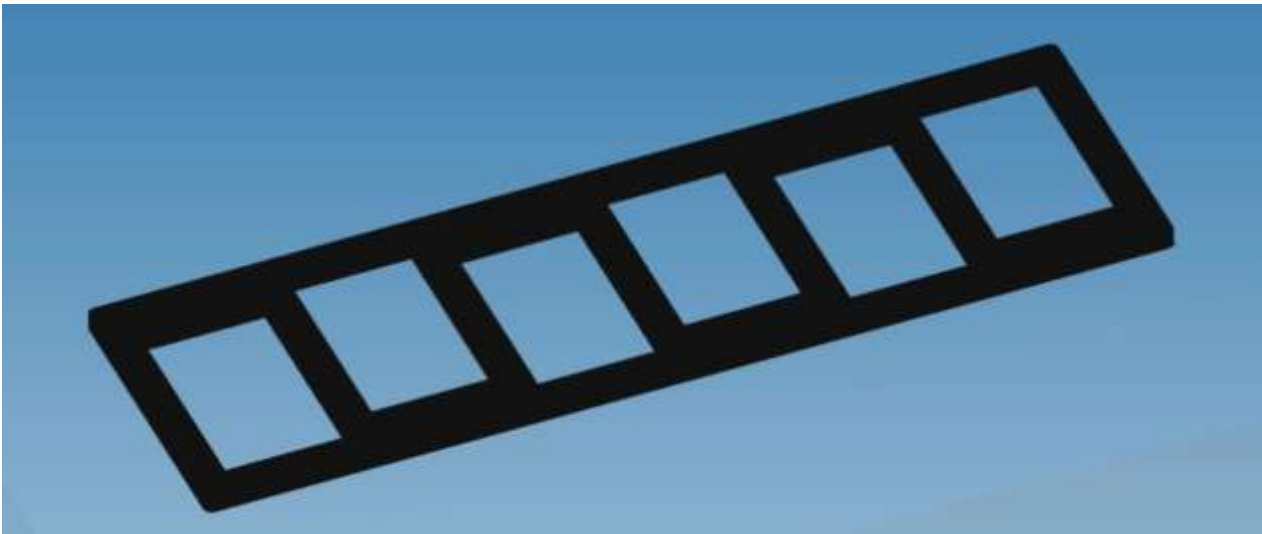

Battery Pack Lid Locator (x1)

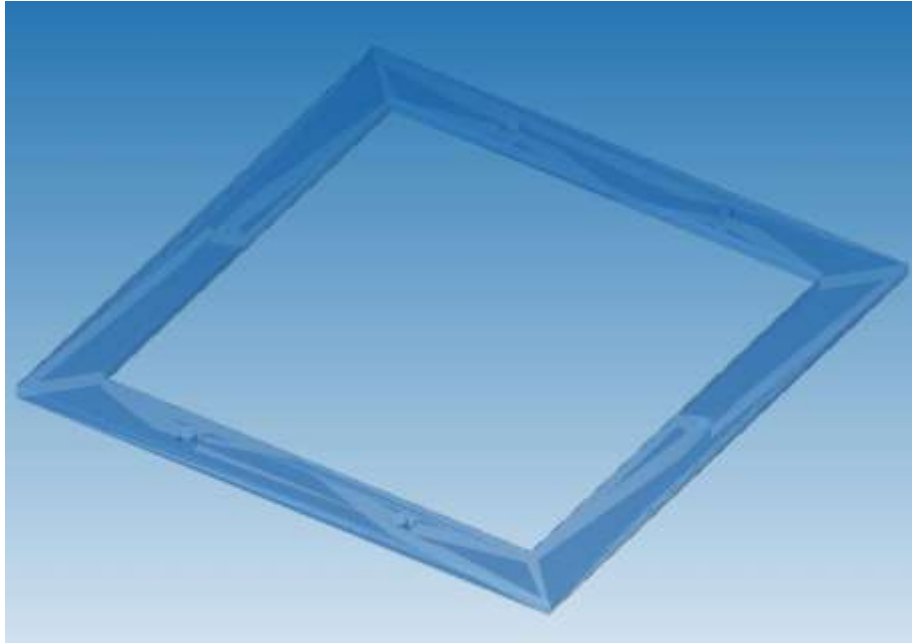

Battery Pack Lid located in Battery Pack Lid Locator:

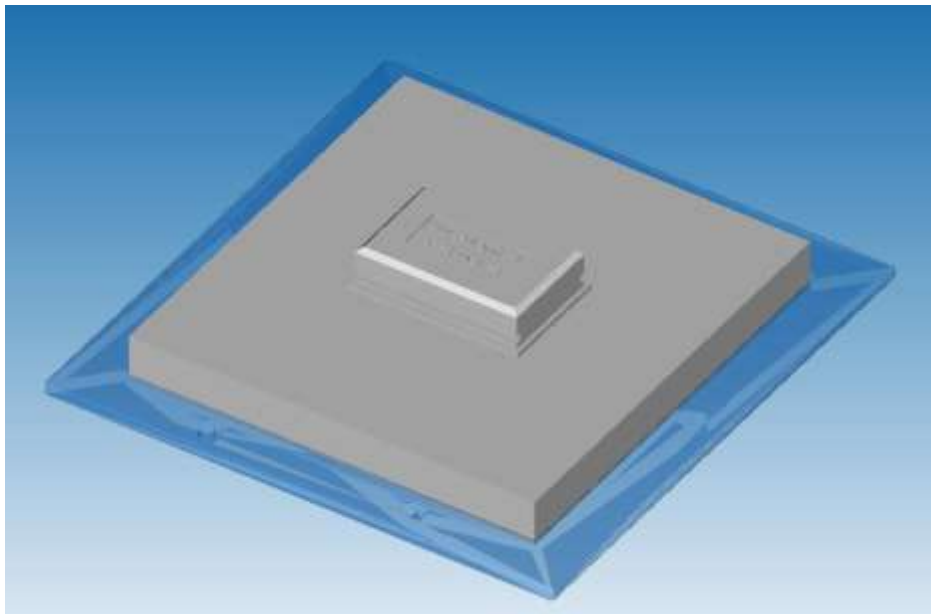

Conveyor, with 2 x Sensors for mounting at the ends of the conveyor.

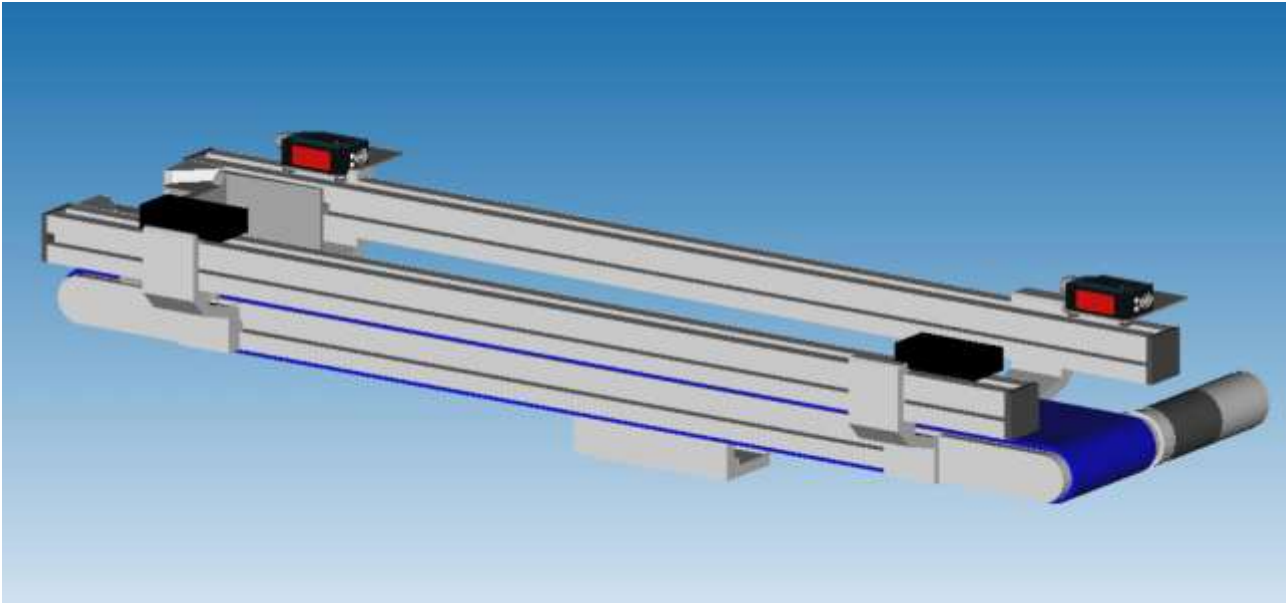

End-Stop, to ensure that the modules stop in a defined position at the end of the conveyor:

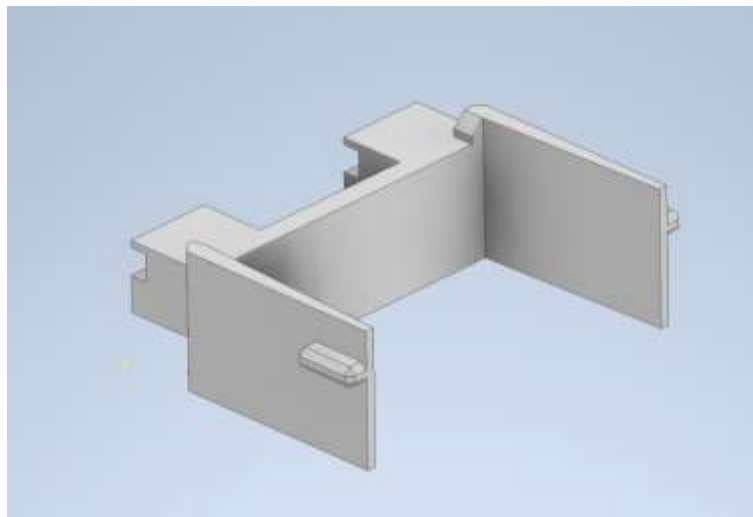

Description – Gripper and Teach Pin (F)

The Gripper assembly

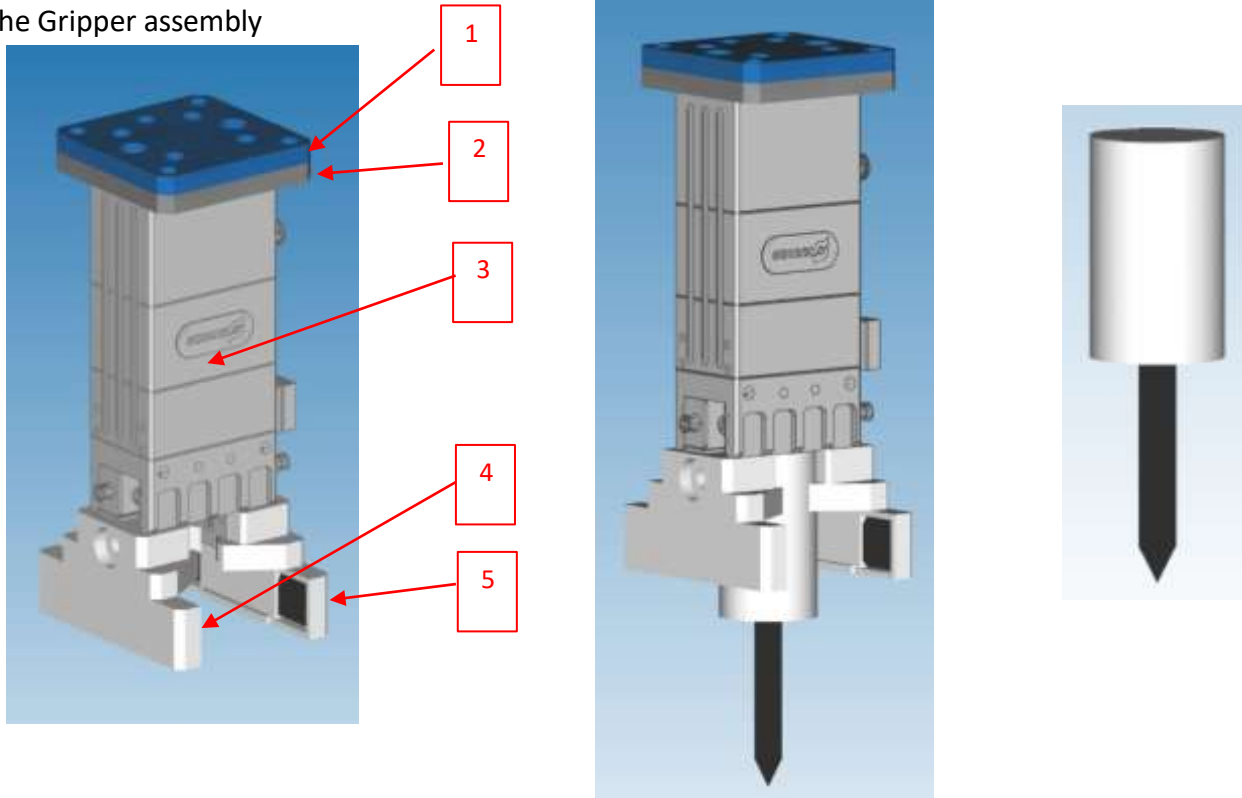

DESCRIPTION	
1	J6 Mounting Plate – to mount the entire assembly onto J6 Ref.: LX0-RO-ZZ-09-10022
2	EGP40 Mounting Plate -to be fix on J6 Plate Ref.: LX0-RO-ZZ—09-10021
3	Schunk EGP 40 – electric gripper
4	Gripper Finger
5	Gripper Finger

The Teach Pin MUST be used to teach accurate reference positions and frames. This also means creating a separate TCP for the Teach Pin.

Description – I/O Block (F)

An I/O Connection Block is supplied to connect peripheral equipment.

The I/O Block has sockets numbered 1 to 8 as shown below:

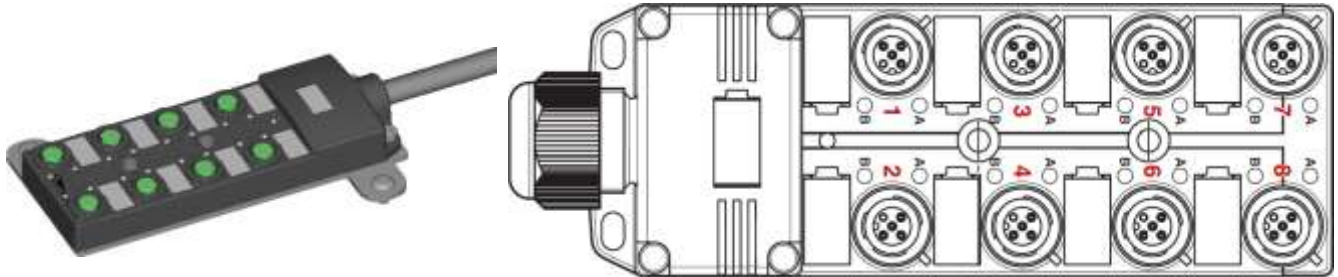

The robot I/O is pre-connected to the sockets as shown in the table below:

SOCKET	A (PIN 4)	B (PIN 2)
1	DI [101]	DI [102]
2	DI [103]	DI [104]
3	DI [105]	DI [106]
4	DI [107]	DI [108]
5	DO [101]	DO [102]
6	DO [103]	DO [104]
7	DO [105]	DO [106]
8	DO [107]	DO [108]

The input and output cables can be connected directly to the socket or via a Y-connector as shown below, to make the most efficient use of the available I/O. Plastic clips are supplied to clip cables to the table if needed – see examples below:



PLEASE NOTE THAT NO ELECTRICAL MODIFICATION OF CABLES OR CONNECTORS OR ANY OTHER COMPONENTS IS REQUIRED OR ALLOWED!

Description – UOP Box (F)

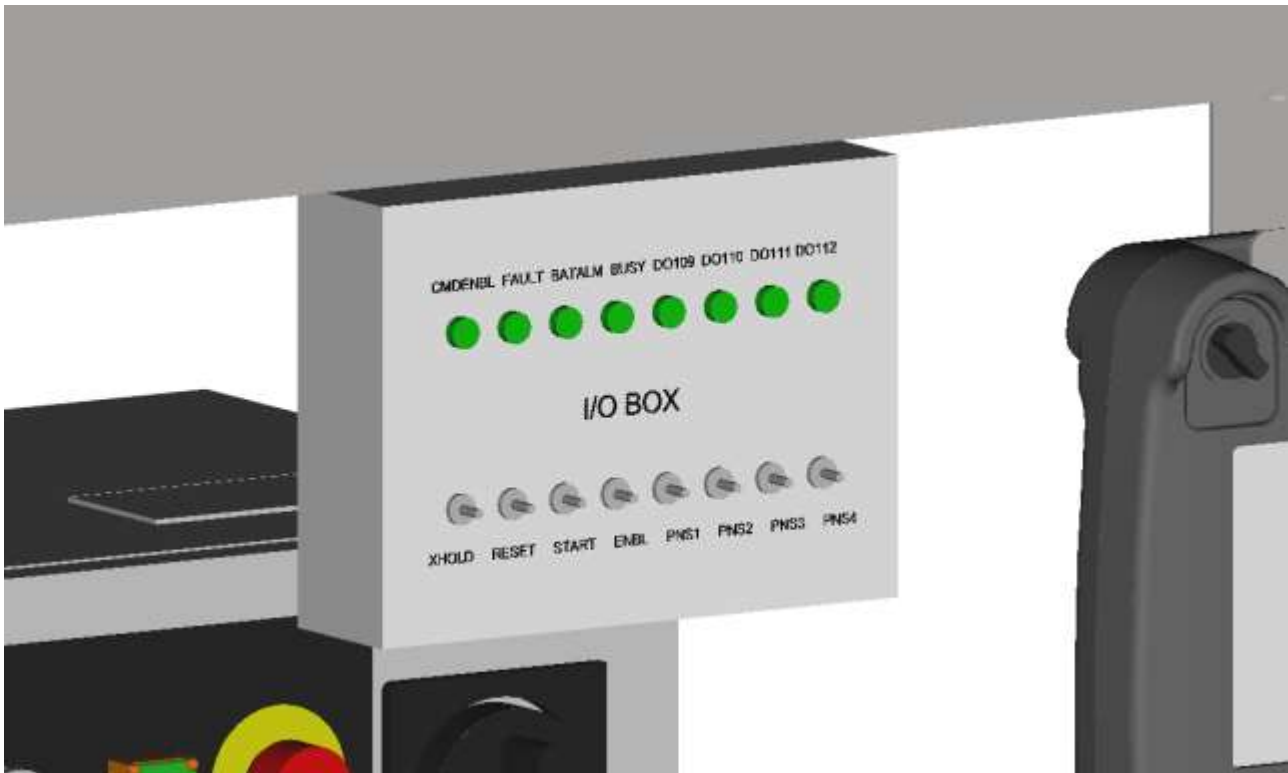

The UOP Box is already attached to the Education Cell and connected to the robot I/O

The I/O is configured as shown on the UOP Box.

The unused DO [n] are available for the competitors to use for any purpose.

If they are used, they should be labelled appropriately.

For details, please refer to the Robot Controller Manual B-83284EN/09, Section 3.3. SETTING UP THE ROBOT SYSTEM

Description – PC and Software (F)

One laptop is supplied, equipped with:

- Mouse
- Microsoft Windows.
- Microsoft Office: Word, Excel, PowerPoint, acrobat reader etc – for Documentation
- Microsoft Office SharePoint Designer for Web Page construction
- Microsoft Internet Explorer for connection to Robot Controller
- FANUC Roboguide for Simulation (and template RG Cell)
- Payload checker
- One USB key for file transfer etc.
- Ethernet cable for connection to robot controller for file transfer etc.
- All necessary FANUC Manuals are also supplied in PDF form on the PC
- HTML Editor
- Manuals
- Payload Checker
- Roboguide

Description – Ethernet (F)

An Ethernet cable is supplied to connect from Laptop to Robot for setup, entering comments, iRVision, etc. There is Ethernet connection cable already installed in robot controller with external connector so there is no specific need to open the controller to make the Ethernet connection.

PC and Robot IP addresses and Subnet Masks should be set as shown below

PLEASE DO NOT USE OTHER VALUES!

IP ADDRESS TABLE		
IP ADDRESS ROBOT 192.168.1.10	IP ADDRESS PC 192.168.1.1	SUBNET MASK 255.255.255.0

If Competitors have trouble setting up the Ethernet connection, then they can ask for assistance, but they will only get points for setting it up themselves.

Description – Basic HMI (F)

A template Basic HMI (User Interface) file is provided - This file should be loaded and set up so that it can be displayed on the Teach Pendant.

It should be possible to display it manually whenever the operator wants to display it, and it should be automatically when the main program is started in Automatic mode.

The minimum functions of the HMI should be:

Display a Counter showing the number of the part being processed.

Display the Open/Closed status of the Gripper

Display the Error/Fault status of the Robot (equivalent to the Fault LED on the TP)



It is not enough to just load this file – it must be set up correctly with correct labels, I/O and Register values and Colours

Competitors can use Microsoft SharePoint designer or a text editor or any other function installed on the PC to modify it.

Competitors may improve/extend this basic HMI as much as they wish.

For further information on the HMI / User Interface Setup please refer to the information on the standard Education Cell: FEC_Ed_Cell_Technical_V5_4.pdf

Description – Advanced HMI (F)

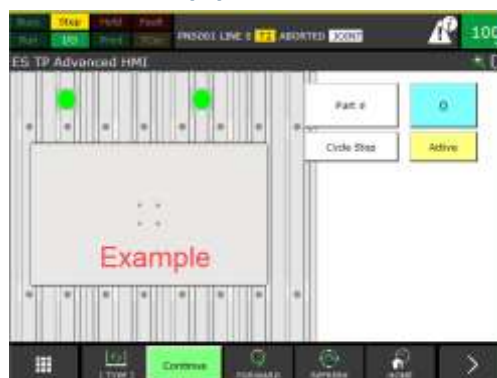

A template Advanced HMI (User Interface) file is also provided.

This shows how to make a more sophisticated User Interface.

Competitors may include some of these advanced features into the HMI for additional points.

Description – Reserved Programs (F)

There are some reserved programs:

Z_SHIP, Z_ZERO, Z_HOME

These are for Workshop Manager, Workshop Manager Assistants and Skill Management Team to use – please do not use/modify/delete these programs

Instructions to the Competitor

Instructions – Basic Task - Parts (C1)

The necessary equipment for the application is supplied:

Battery Module 15 AAA (x4)

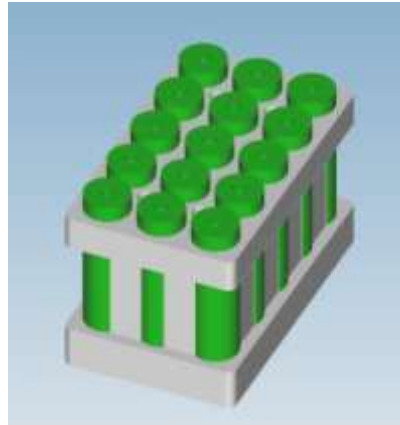

Control Module (x1)

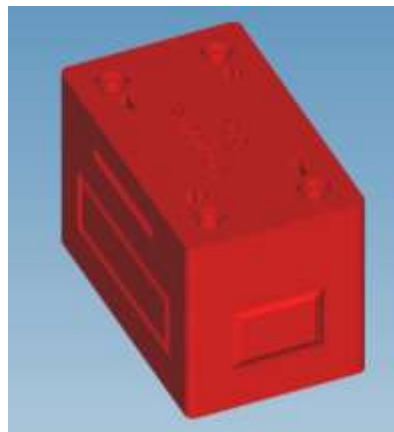

Instructions – Robot Setup – Gripper (C1)

Mechanically and electrically install and connect the gripper. Set up the robot system to use it. Additional marks will be awarded for the most complete setup.

Set up the Robot payload(s) according to the data given:

ITEM	DESCRIPTION	MASS (GRAMS)
1	Total Mass of mounting plates and screws	60
2	Mass of gripper body	320
3	Mass of one finger	16
4	Mass of Battery Module Full	206
5	Mass of Control Module	40
6	Mass of Battery Pack Lid	110

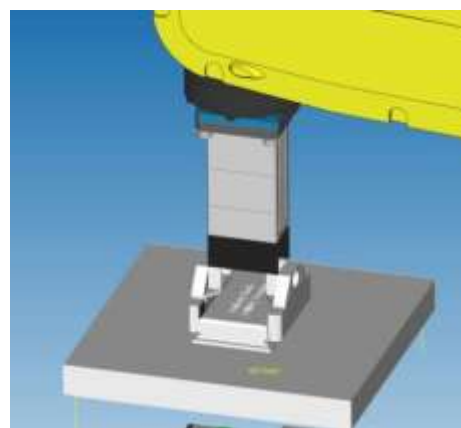
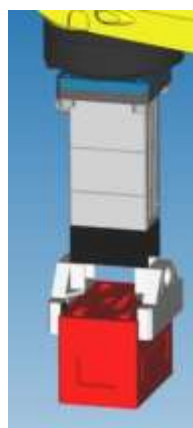
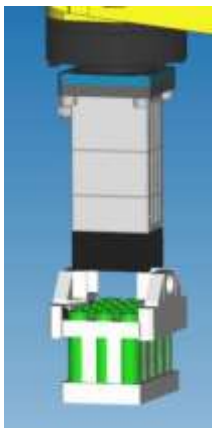

Set up also appropriate TCP – Tool Centre Point – for the gripper and for the Teach Pin as a minimum.

Instructions – Gripper Test Run (C1)

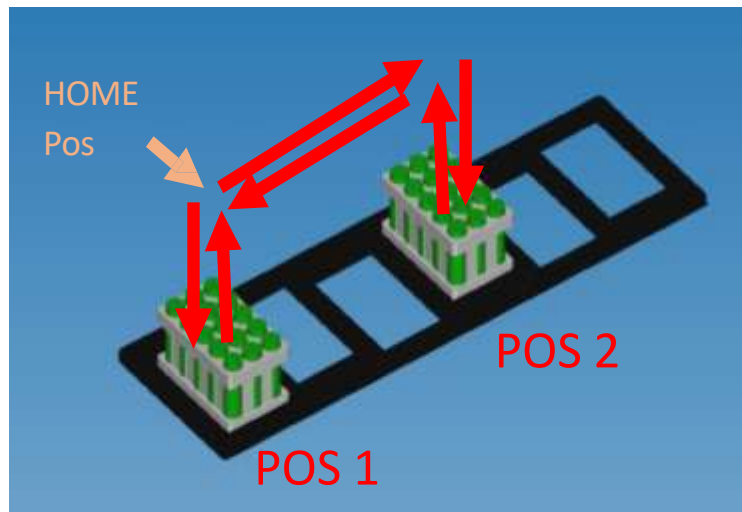

The first task in the Test Project is a simple test that the gripper is correctly set up and working.

Program this sequence:

STEP	ACTION
1	Start at 100mm above the Module in Pos 1 with Gripper Open
2	Move down to Position 1, close gripper, move up above Position 1
3	Move above Position 2
4	Move down to Position 2, open gripper, move up above Position 2
5	Move down to Position 2, close gripper, move up above Position 2
6	Move above Position 1
7	Move down to Position 1, open gripper, move up above Position 1
8	Repeat steps 2-7 for 3 cycles
	All up/down movements are 100mm

The program can be run in Auto or Manual mode, but additional points will be given for running from the UOP Box in Auto mode.

The robot should be moved to the described start position before starting the test program so that experts can check it is correct.

Test Run Conditions: three (3) cycles, three (3) attempts, total five (5) minutes.

Correctness of task and Cycle Time will be measured.

Instructions – Basic Task (C2)

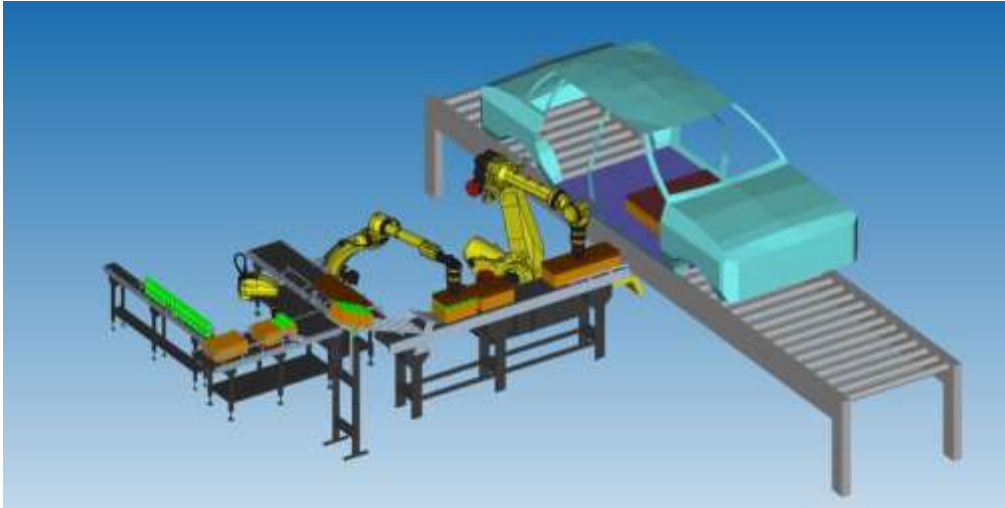

In an Electrical Vehicle factory many robots can be used for different purposes, as shown above – small robots for handling individual battery cells, larger robots for handling battery modules and large robots for handling complete vehicle battery packs.

The Basic Task is to simulate the Automation of one Battery Pack Assembly, but instead of multiple robots, we will use only one robot.

STEP	ACTION
1	The Robot starts and ends the task at a Home position. It should not start the task unless it is at Home.
2	Unload one battery or control module from the Module Magazine [1]
3	Load the module onto one end of the Conveyor [2], and then activate the Conveyor to move it to the other end [3] of the Conveyor
4	After the module is picked from the conveyor it must be placed in the Battery Pack Body. The final locations of the modules must be as shown [4]
5	Sensors mounted on the Conveyor must be used to check that the system is operating correctly and a program to manage the start and stop of the conveyor needs to be created.
6	After the Battery Pack Body is full of Modules, the Battery Pack Lid should be mounted on top of the Battery Pack Body
7	A creative HMI should be implemented to provide an easy to use interface for a human operator

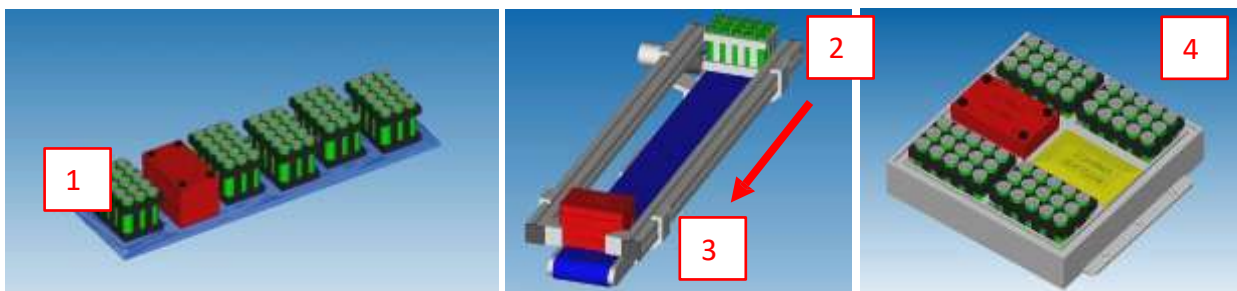

Instructions – Basic Task Sequence (C2)

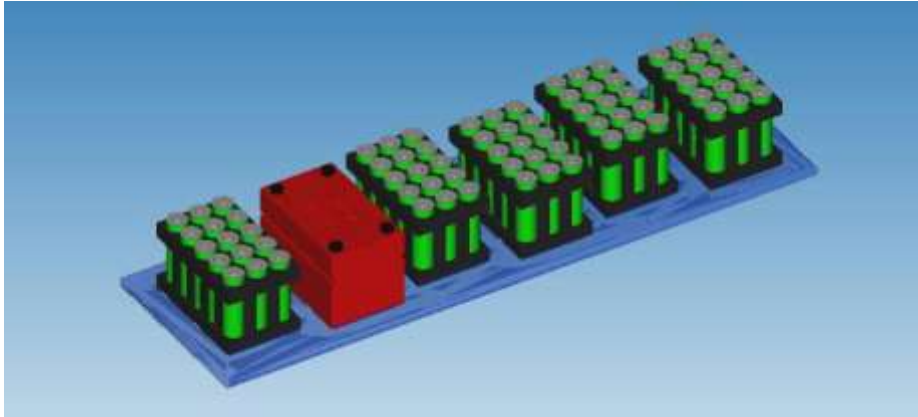

Above is an example of a possible loading of the magazine module. In

this example the positions of the modules are:

Magazine Position	1	2	3	4	5	6
Module Type	Battery Module	Control Module	Battery Module	Battery Module	Battery Module	Spare Battery Module

The actual positions of the modules for the Test Run will be given to the Competitors one hour before the end of C2, so one hour before Assessment so the robot should be programmed in a way that can easily be changed when the module positions are changed.

The competitors will also be marked against the total robot cycle time for this task. Quicker cycle times will be rewarded as well as accuracy of path and positions.

Test Run Conditions: five (5) Modules + one (1) Lid, three (3) attempts, total eight (8) minutes

Correctness of task and Cycle Time will be measured.

Instructions – Extension Task (C3)

Simulation of Sealant Dispensing on Battery Pack Lid

In addition to the Basic Task, you need to setup a simulation of dispensing sealant on the Battery Pack Lid. The Dispensing System simulator, consisting of a whiteboard marker mounted on an air cylinder controlled by pneumatic valves, must be installed as shown below and electrically and pneumatically connected.

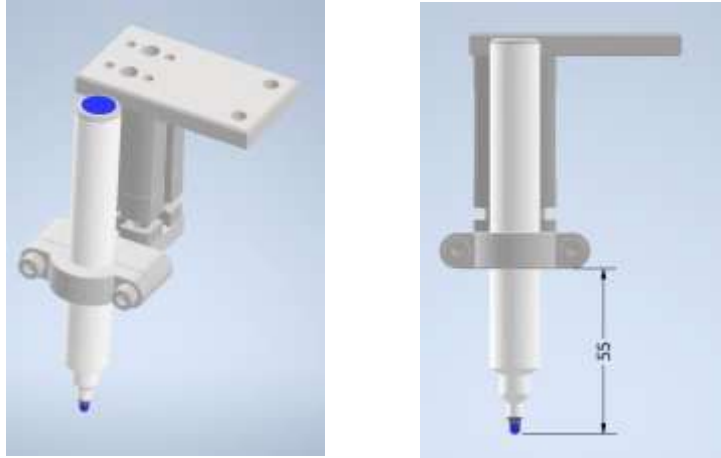

The distance between the tip of the pen and the lower end of the pen clamp must be 55mm. The distance between the mounting bracket of the dispenser system and the front cell frame must be 190mm.

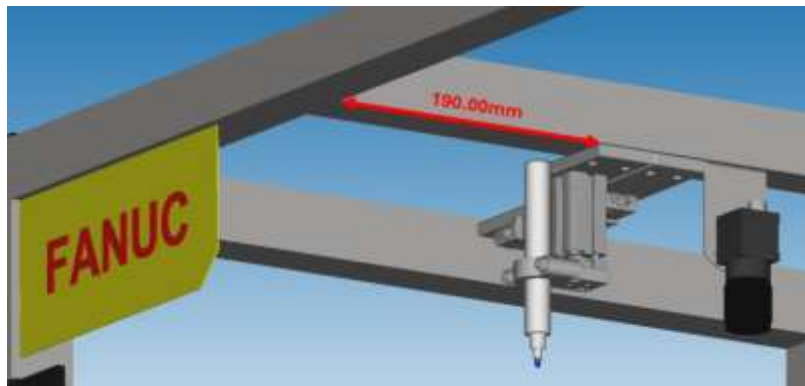

To simulate the ON/OFF function of the Sealing equipment, an air cylinder is used to move the Dispense tool Up and Down.

In the DOWN position the Gun is ON (Fig 1) and in contact with the parts, and in the UP position the Gun is OFF (Fig 2)

Fig 1: DOWN / ON



Fig 2: UP / OFF



For programming the Dispensing movement, the RTCP (Remote Tool Centre Point) function should be used.

See B-83284EN-2/10 OPERATOR'S MANUAL Optional Function – Section 7 REMOTE TCP FUNCTION

The minimum requirement is to mark one continuous bead around the underside of the lid:

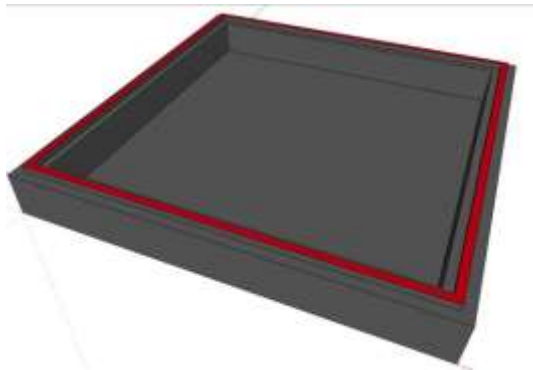

Under side of the lid:

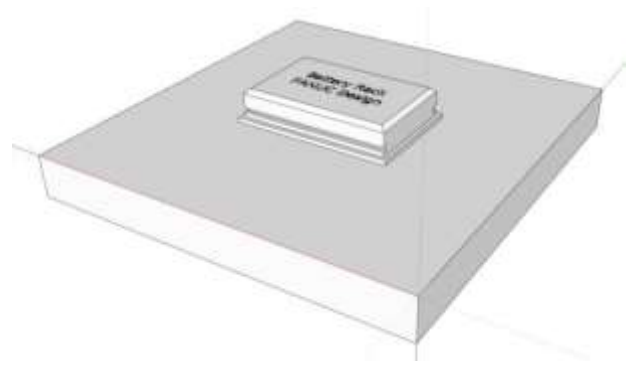

Top side of the lid:

Additional points will be awarded for marking a bead around the lid with the pattern shown below, by turning the Sealing Gun ON and OFF (DOWN and UP), at different positions along the path.

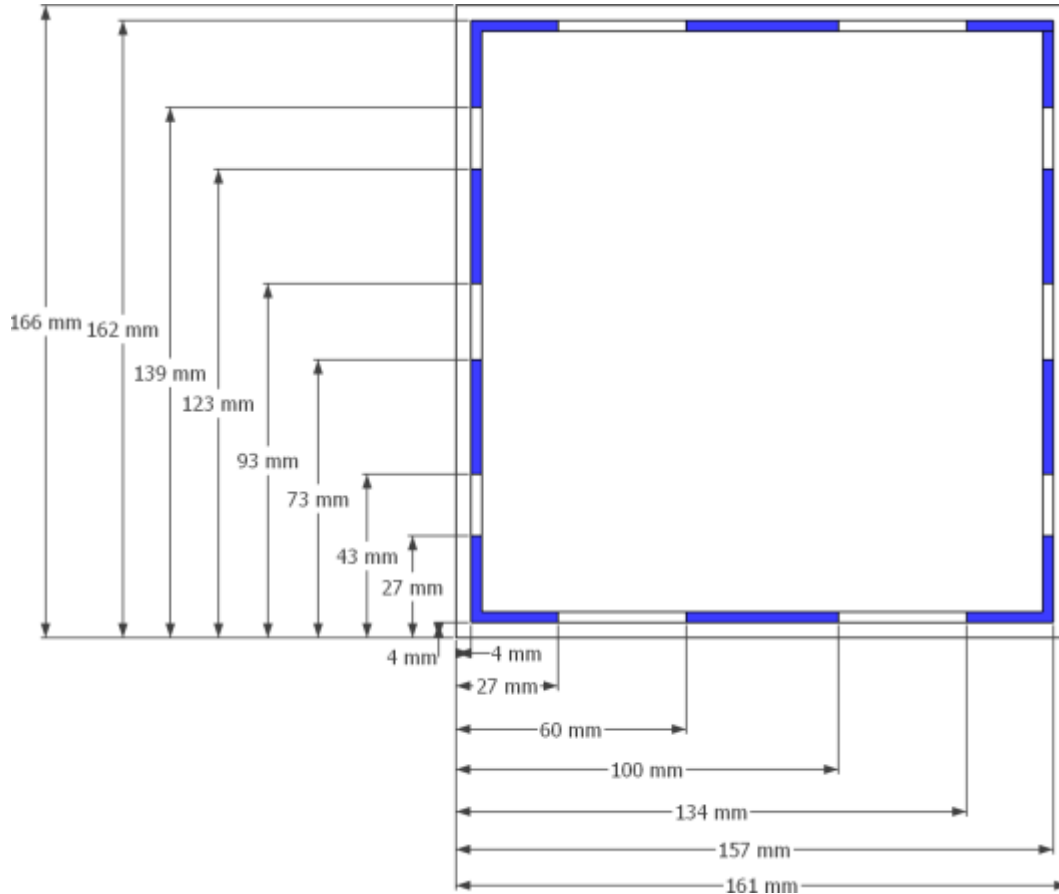

Test Run Conditions: six (6) Modules + cover + sealing, three (3) attempts, total eight (8) minutes.

Correctness of task and Cycle Time will be measured.

Instructions – Working Style and Safety (F)

Throughout the Competition, Competitors will be expected to work as if they are in a real Industrial setting – installing and setting up a Robot System at a Customer site.

This means always working professionally and taking all normal precautions against events which may occur in a real industrial situation.

Instructions - Roboguide/Digital Twin (F)

Simulation plays an important role in this skill.

- Planning the layout of the cell and checking reachability of cell components.
- Creating the basic task program structure while the equipment is being installed according to the layout
- Creating the extension task program structure while the basic task structure is being installed and tested

It is also important that any changes that are found during installation and testing are implemented in the Simulation as well as on the real cell – so that there is a Digital Twin of the actual cell – the layout, the programs – all aspects of the cell.

First you will be asked to create a Roboguide program to check reachability of the components in the cell. Later it will be checked if the Roboguide simulation is really a Digital Twin of the real cell.

Remember also to make the Teach Pendant display as realistic as possible – for example with the 4D Graphics function, and to work professionally with the laptop as well as with the Robot.

Instructions –Documentation (F)

When you have finished the task, you should hand over a documentation package to the end customer. This documentation should contain all the information necessary to run, maintain and troubleshoot the cell after you leave site.

You have been provided with a template document in English for the documentation package. The documentation can also be done in Spanish.

Instructions – Robot and PC Power (F)

At the end of every Day of competition, the competitors should turn robot and PC power OFF. The experts will tell the competitors when to turn power ON again before marking.

Instructions – Test Running and Test Run Timer (F)

Test Running will be done according to the Technical Description – 3 attempts in a specified amount of time, first successful attempt ends test run.

To measure the Cycle Time, the competitors should insert the RUN START_TIMER command as shown below into each main program.



```

YOUR_PROGRAM LINE 0 T2 ABORTED JOINT 100
YOUR_PROGRAM 7/7
1: RUN START_TIMER
2: !Your Remarks
3: !Your Program....
4:
  
```

Hint: [INST] > Multiple control > RUN > COLLECT > KAREL Progs > START_TIMER
 It may be necessary to enable KAREL to make the program START_TIMER visible:



```

SYSTEM Variables 340/866
331 $KAREL_ENB 1
332
  
```

The timer value will be shown in R [200] – this register is reserved for this purpose:



```

DATA Registers 196/200
R[200:Reserved ]=0
  
```

The Marking Team will check that this has been correctly done before starting the test run

IF COMPETITORS HAVE ANY QUESTIONS OR CONCERNS ABOUT THE USE OF THE START_TIMER PROGRAM THEN THEY SHOULD ASK DURING COMPETITION TIME, NOT DURING MARKING TIME.

Materials, equipment, and tools prohibited in the skill Area (F)

PERSONAL LAPTOPS – USB – MEMORY STICKS– MOBILE PHONES

Competitors are only allowed to use memory sticks provided by the Competition Organizer.

Memory sticks or any other portable memory devices cannot be taken outside the workshop.

Memory sticks or other portable memory devices are to be submitted to the Technical Coordinator at the end of each day for safe keeping.

Experts are allowed to use personal laptops, tablets, and mobile phones in the Expert room only.

Competitors are not allowed to bring personal laptops, tablets, or mobile phones into the workshop.

PERSONAL PHOTO CAMERAS – VIDEO TAKING DEVICES

Competitors and Experts are allowed to use personal photo and video taking devices in the workshop at the conclusion of the competition only.